

# AFRON

## POWER LADDERS

ELEVATED WORKING PLATFORMS

*Making  
hard work easy!*



**QUINTO**  
AG SUPPLIES

Manufactured  
to Australian standards by  
**QUINTO AG SUPPLIES**

75 Kennedy Highway, Tolga Q 4882

✉ [quinto70@bigpond.com](mailto:quinto70@bigpond.com)

☎ 0455 600 190



# Designed with you in mind...

The extensive range is made up of the LPA350, LPA400, PA500, PA600 and the PA650. These machines offer platform heights of 3.5 through to 6.5 metres. The various platform heights ensure that there is a unit to help you get more done, more reliably, for less.

A unique design hydraulic system, using quality hoses and components, offers excellent fuel economy and low noise levels. All hoses are fully enclosed in the boom offering clean lines with no exposed hoses.

Enjoy a lower cost of ownership due to the machines' durability and easy maintenance. Refuelling and access to daily checkpoints is quick and easy. Combine these features with all the productivity gains and you have an unbeatable combination.

Each machine in our range meets Australian Standards 1418.10 and 2550.10 has design registration and complies with OH&S requirements nationwide for your peace of mind.

**When you add it all up,  
the PA Series looks good  
from any angle!**

## WHY AFRON?

- ✓ Every Afron machine is backed by over 30 years of practical experience. Thousands of machines are operating throughout Australia and the world. It is field proven technically and economically.
- ✓ Afron elevating work platforms are manufactured from the highest quality components and materials for dependability and ease of service.
- ✓ The latest models include galvanised wheels and 2 pack paint for added durability.
- ✓ The design is continually improved with thought from both technical and operational points of view.
- ✓ An extensive range of optional accessories allows you to specialise a machine to suit your application.
- ✓ A nationwide Afron dealer network ensures that the supply of service and spare parts is readily available.
- ✓ You can increase productivity and save up to 50% on your labour costs. That means more money in your pocket.

## STANDARD FEATURES OTHERS DREAM ABOUT!

Failsafe, fully enclosed brakes including over centre valves and free wheel function for towing  
Heavy duty, rough terrain drive tyres  
Dual foot and hand controls  
Digital hour meter  
Steel, lockable, engine covers  
Harness attachment point and mid rail on platform  
1 year comprehensive warranty  
Choice of engine options

## BUILD A MACHINE TO SUIT YOU

### Options available:

- Picking container with mid door
- Slew bucket system
- Two speed system
- Audible inclination alarm
- Safety harness & lanyard
- Front mounted forks
- Air compressor
- Bucket padding
- Dual caster wheels
- Pruning tool boxes
- Puncture proof tyres

PA Series EWP's offer low centre of gravity, high ground clearance and long wheelbase delivering unsurpassed balance and agility for smooth moves regardless of what's underfoot.





## FEATURE

## BENEFIT

Dual hand and foot controls	<ul style="list-style-type: none"> <li>■ The operator can raise and lower the tower and drive the Afron with either set of controls.</li> <li>■ Operators can use the controls that feel comfortable for them</li> </ul>
Failsafe brakes as standard	<ul style="list-style-type: none"> <li>■ When operating on slopes the Afron is stationary and does not roll or gradually slip.</li> <li>■ Maximum efficiency is achieved by operators as they can work without having to counter the effects of the machine rolling.</li> </ul>
Versatile engine options	<ul style="list-style-type: none"> <li>■ Honda, Vanguard or Kubota petrol and diesel options available.</li> <li>■ Allows you to specify the engine to achieve the maximum efficiency.</li> </ul>
Large range of optional accessories	<ul style="list-style-type: none"> <li>■ Allows the machine to be built with the options needed to assist with operator efficiency</li> </ul>
9.5 degree side slope rating on LPA 350 & 400 models	<ul style="list-style-type: none"> <li>■ Owners can match slopes on their property to the machine rating. LPA 350 &amp; 400 models</li> <li>■ Operator safety.</li> <li>■ Access to areas that have large side slopes.</li> </ul>
8.0 degree side slope rating on PA500,600 & 650 models	<ul style="list-style-type: none"> <li>■ Owners can match slopes on their property to the machine rating.</li> <li>■ Operator safety.</li> <li>■ Access to areas that have large side slopes.</li> </ul>
High powered wheel motors	<ul style="list-style-type: none"> <li>■ Enables the machine to climb slopes of up to 20 degrees.</li> </ul>
Low tail height	<ul style="list-style-type: none"> <li>■ Allows machine to swing under trees when picking &amp; pruning.</li> <li>■ Prevents tree damage.</li> <li>■ Increases the access areas in tight orchards.</li> </ul>
Level arm and hydraulic hoses enclosed in boom	<ul style="list-style-type: none"> <li>■ Prevents the danger of becoming caught up in trees.</li> <li>■ Prevents the damage potential to trees.</li> <li>■ Hoses are secure and the risk of fraying and becoming caught is reduced.</li> </ul>
Control valve mounted on platform	<ul style="list-style-type: none"> <li>■ No cables</li> <li>■ Smoother operation</li> <li>■ Easier fault finding when necessary</li> </ul>
Unique hydraulic system	<ul style="list-style-type: none"> <li>■ Excellent fuel economy</li> <li>■ Low noise levels</li> </ul>
12 Month Comprehensive Warranty	<ul style="list-style-type: none"> <li>■ On all parts for your total peace of mind &amp; confidence in our product.</li> </ul>

## DO MORE WITH LESS EFFORT

The Afron PA Series elevating work platforms are engineered with the strength, power and reach to take operators to greater heights. If you want a machine that is preferred by operators and will provide you with an instant rise in productivity -

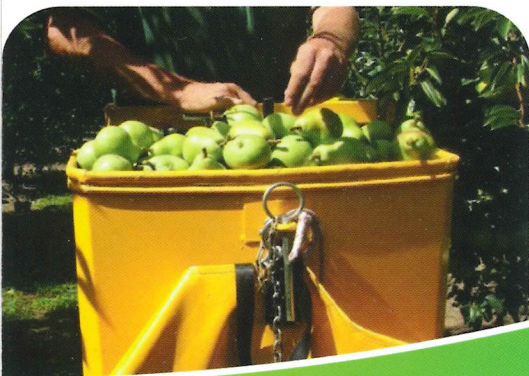

*The Afron*

*PA Series is the answer.*

[afron.com.au](http://afron.com.au)



## SPECIFICATIONS

- Operation & Maintenance Manual
- EWP Logbook & Safety book
- Floatation Bear Claw or Goodyear
- Mud Runner drive tyres
- Failsafe wet brakes with freewheel hubs
- Ballast Weights
- Compliance plates & safety decals
- Digital Hour Metre
- Side Tilt Inclinator Hand controls
- Lift gate & midrails on platform
- Lockable steel engine covers
- Choice of engine options

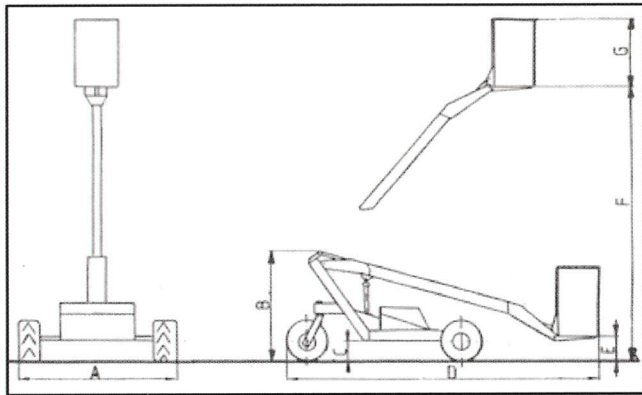

*Making  
hard work easy!*



Model	A	B	C	D	E	F	G	Weight Kg	Platform S.W.L (Kg)
LPA350	1960	1200	260	4500	450	3500	900	1000	180
LPA400	2200	1200	260	5100	450	4000	900	1050	180
PA500	2350	1500	260	5800	450	5000	900	1100	180
PA600	2400	1500	260	7000	500	6000	900	1300	150
PA650	2420	1500	260	7500			900	1400	150

Your nearest **AFRON** reseller is:

**SUPPLIED BY**



*Support Australian manufacturers.*